



InLcader

SEMI-AUTOMATIC
SYSTEM FOR LOADING
AND UNLOADING
SHEET METAL

logitower.eu

Basic

InLcader

InLoader BASIC - sheet metal loading system

- loading on cutting machine table
- semi-automatic process
- sheet metal loading

Sheet metal parameters

Sheet metal length	1000 - 3000 mm
Sheet metal width	1000 - 1500 mm
Sheet metal thickness	0,5 - 25 mm
Sheet metal weight (max)	900 kg

System data

vertical velocity (max)	0,2 rad/sec
power	5,5 kW



- quick installation
- suction cup module picking sheet metal
- magnetic separation of sheet metal

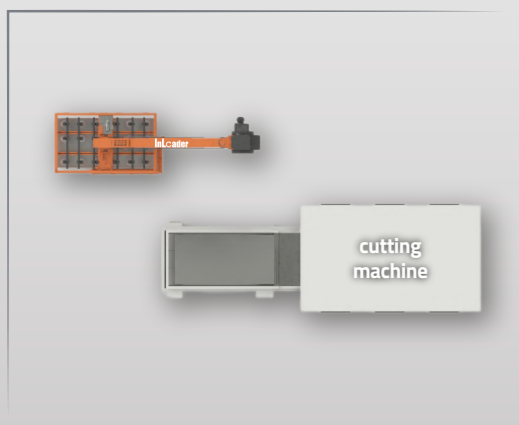

InLcader⁺

Plus

InLoader PLUS

- additional feature of collection of cut elements by fork module
- putting aside for picking and sorting

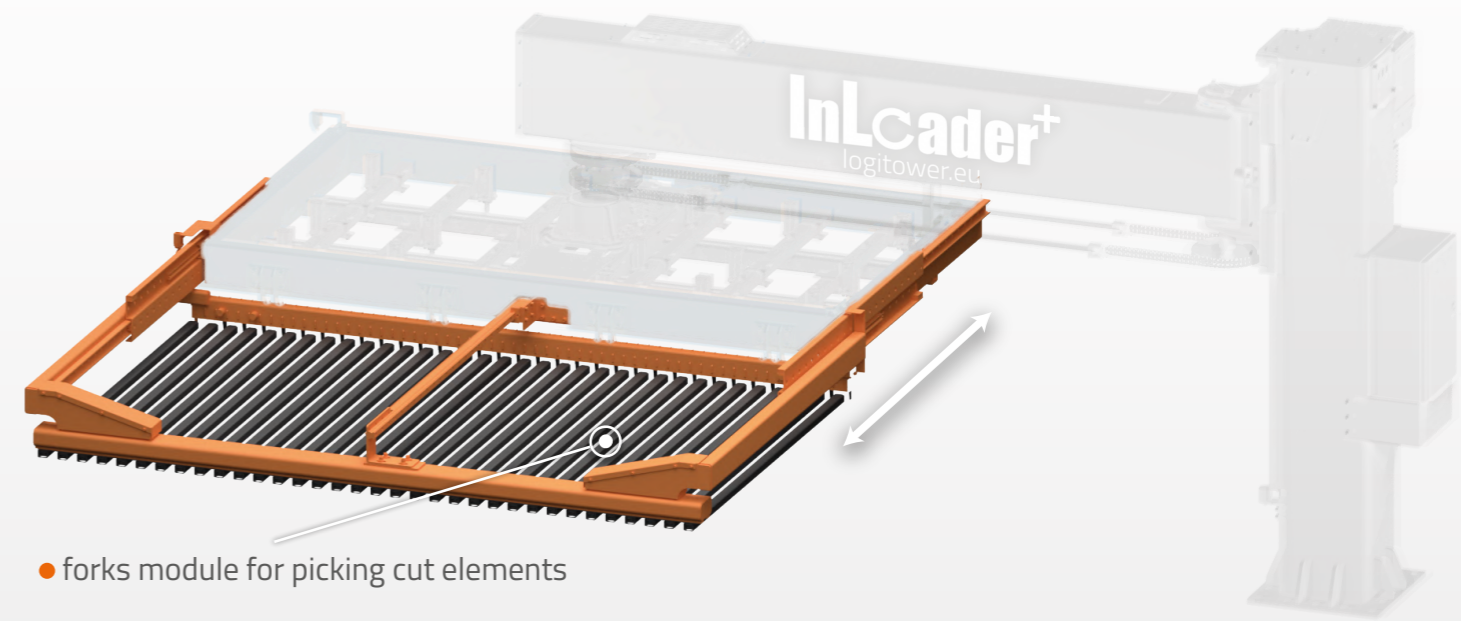

- forks module for picking cut elements

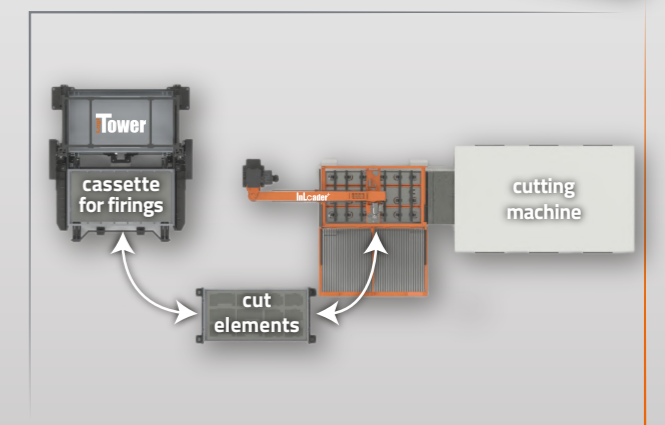
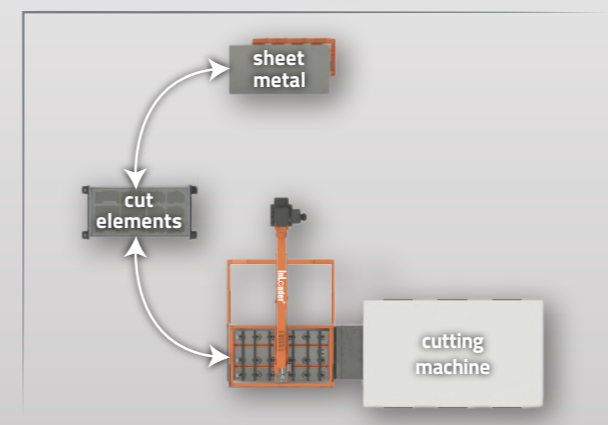
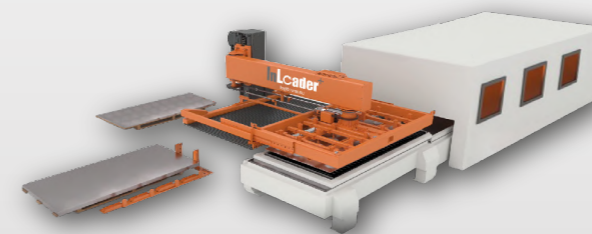



Logi Tower
logitower.eu

InLcader

Logi Tower Loader

Logi Comb

✉ info@logitower.eu

🌐 logitower.eu